

Incident Investigation Summary Report

Date of Report	23.09.2008	Incident Report Number	
Employee	X	Contractor	Visitor
Date	15.09.2008	Time	11:45

Incident Classification:

Lost Time Injury	X	Medical Treatment Case (With High Potential)		First Aid Case (With High Potential)		Near Miss (With High Potential)	
------------------	---	---	--	---	--	------------------------------------	--

Description of the accident:

The worker was to clean the clogged suction pipe of the bisulfite-stage-1 chemicals recovery system, using the XX high pressure cleaning equipment. The clogged section of this pipe is 2 meters above the ground and the worker was thus doing the cleaning while sitting on top of a 8-rung stepladder. An assistant worker for the high pressure cleaning equipment, at a distance of approximately 10 m signalled the release, and the worker started the cleaning work. The danger zone was visually controlled by the assistant worker (to prevent general access).

A high-pressure pistol with a 450-mm nozzle pipe was used for cleaning. The overall-length from the trigger guard of the pistol to the end of the nozzle pipe was 700 mm.

The worker held the high-pressure pistol at the trigger guard with his right hand and stabilised the nozzle pipe with his left hand. The reaction of the water jet, accidentally directed at an obstacle, pushed the high-pressure pistol and his right hand backwards and the nozzle pipe off his left hand.

The water jet hit and penetrated the left forearm of the worker approximately 80 mm above the palmar carpal region.

The worker, after first-aid treatment from his fellow workers, was immediately transported to the hospital by ambulance.

At the time of the accident, the worker wore the following personal safety equipment:

- Safety rubber boots with toe-protection caps
- Overall
- Gloves (with under-gloves)
- Safety helmet with integrated face protection guard
- Goggles
- Ear protection

The examination in the hospital established the following:

- Left lower and upper arm "pumped up" with a mixture of water and air
- Injured blood vessels
- Injured index finger nerve

The injured worker is the foreman of the Kematen powerhouse. This experienced and well-trained employee was verifiably trained by the supplier of the high pressure cleaning equipment when the equipment was put into operation on January 1999. He has worked with the equipment and its auxiliaries regularly for more than 9 years and has instructed other employees in the use of the high-pressure cleaning equipment and its auxiliaries.

Data of the high-pressure cleaning equipment

- Machine type: XX – 752 P 30
- Serial number: 50925
- Type of high-pressure pistol: XX – HP 750-2
- Built in 1998, supplied on 26.01.1999
- max. operating pressure 370 bar
- Operating pressure at the time of the accident 300 bar
- max. discharge 73 l/min
- The plant operates exclusively with cold water and no additives (cleaning agents)
- The plant is checked once a year by an employee for leakages and damaged parts or components such as pump, valves, hoses, high-pressure pistols, nozzle pipes and also for its overall operation.
- Additional check from the manufacturer each second year. Done 2007, 2005, 2003.

Pictures



Place of accident



Employee working with the high-pressure pistol



Position when injured



High-pressure pistol



Slit glove



Glove and Overall

Essential causes of the accident:

The accident analysis revealed several factors that contributed to the accident:

1. Missing or wrong assessment of risk and danger in the use of high-pressure cleaning equipment and auxiliaries.
2. Use of unsuitable tool
 - Short nozzle pipe
 - No hand grip on nozzle pipe used
3. Work of such kind on ladders is accident prone on account of the rather insecure and unstable working position
4. Wet and slippery nozzle pipe, as well as wet gloves do not permit a sufficiently firm grip.

Conclusion:

Prior to any activity, a risk assessment is to be made:

1. Which dangers may arise, for me and for others?
2. How can I protect myself and others against these dangers?

The following measures for the use of high-pressure cleaning equipment were taken immediately after the accident:

- If not explicitly revoked, no high-pressure cleaning pistols with nozzle pipes shorter than 1000 mm may be used.
- The use of high-pressure cleaning equipment on ladders is forbidden. It must be ensured that a safe and secure working position (permanent stand, scaffolding, lifting platform, etc.) is maintained throughout the cleaning work. There will be no cleaning work done and supervisors will have to be asked for appropriate measures if these requirements cannot be met.

Other measures:

High-pressure pistols and nozzle pipes with forced two-hand triggering (similar to press operation) are commercially available. Technical solutions and improvements shall be discussed with the producer on September 23, 2008, as we intend to use in future only high-pressure pistols with nozzle pipes (independent of their lengths) that are exclusively furnished with two-hand triggering.

It will also be checked with the supplier if the system can be retrofitted so that the water pressure (jet) build-up is gradual when the high-pressure pistol is triggered.

The working area, when working with the XX high-pressure cleaning equipment, is to be closed off at a radius of 10 m.

All activities with XX high-pressure equipment require the release of an appropriate working permit (AES).

Perfection in Ergonomy and Safety:

Constructive details for workers' safety and protection, illustrated on a high-pressure gun type HP 3000-E-EXI-Z

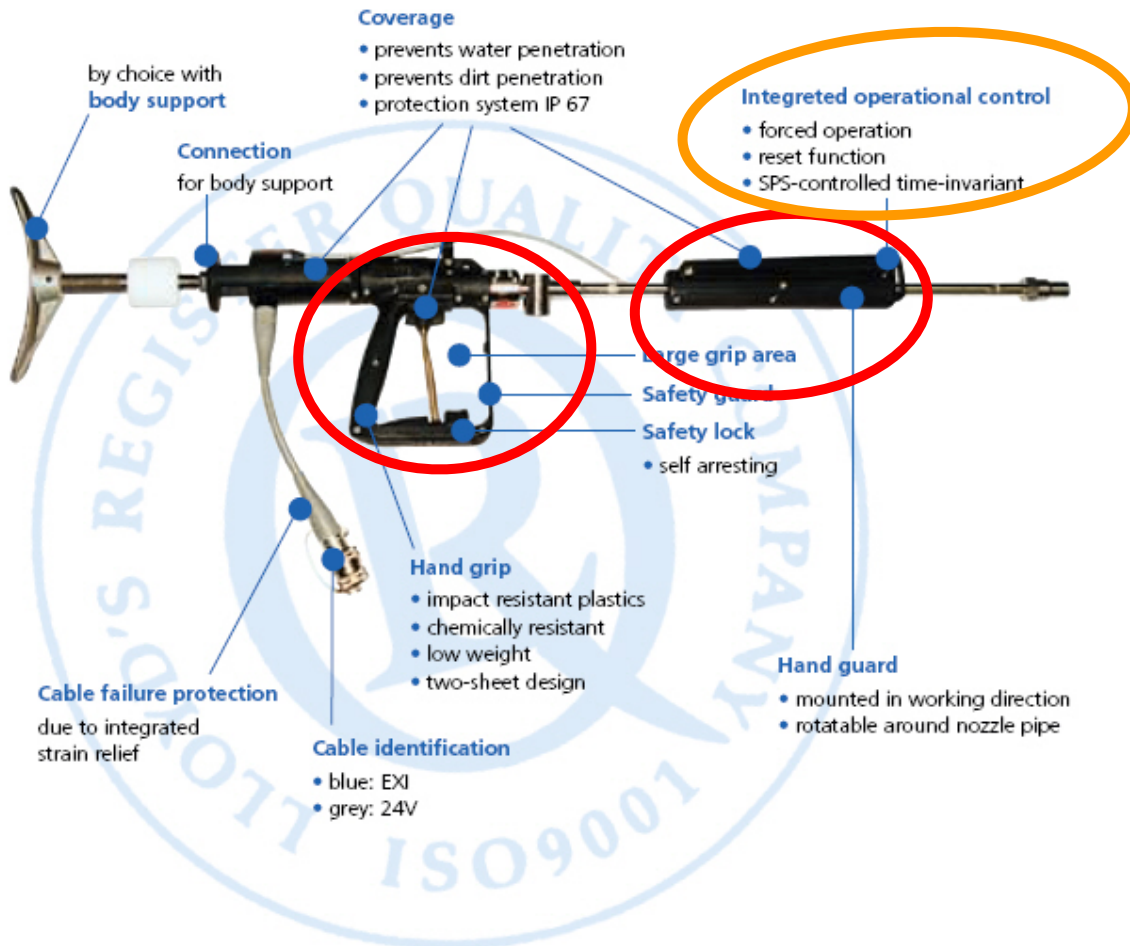

High-pressure pistol with forced two-hand operation

Action plan:

No.	Description	Responsible Person	Due date	Date of completion
1	Implementation of immediate measures			
2	Information of all employees and affected external companies about the accident and the immediate measures in order to prevent injuries when using high-pressure cleaning equipment.			
3	Exchange of all XX high-pressure pistols with pistols that are equipped for only two-hand triggering			
4	Clarification concerning possible retrofitting to permit a gradual pressure build-up after the pistol is triggered			
5	Instruction of all affected employees as to the ban on high-pressure cleaning work on ladders. It must be ensured that a			

	safe and secure working position (permanent stand, scaffolding, lifting platform, etc.) is maintained throughout the cleaning.			
6	All activities with WOMA high-pressure cleaning equipment require the written release of a relevant working permit (AES).			
7	Preparation of checklists (SME form) for working with XX high-pressure cleaning equipment.			
8	Renewed instruction of all employees who generally use high-pressure cleaning equipment: <ul style="list-style-type: none"> - Content of the operating instructions - Existing evaluation of "working with liquid jets" - Training in the use of the equipment 			
9	Revision of the risk assessment – update with findings from the incident investigation			

Meeting of October 28, 2008

A thorough analysis of item 3 of the planned measures showed that the use of high-pressure pistols with forced two-hand triggering would not reduce the potential danger (practical test with producer and external contractor). Opening of the two-hand contact reduces the pressure so slowly that one of the hands could accidentally be moved dangerously close to the nozzle before the pressure has come down to zero. The following alternative measures have been taken instead:

Action Plan:

No.	Description	Responsible Person	Due Date	Completion Date
1	Two new high-pressure pistols will be bought featuring a gradual pressure build-up when the trigger is actuated.			
2	All XX equipment will in future be used only with jet pipes having a second hand grip (see illustration).			
3	The personal safety equipment will in future be complemented with overshoes and with an appropriate high-pressure-jet-resisting hand protection (see pictures).			

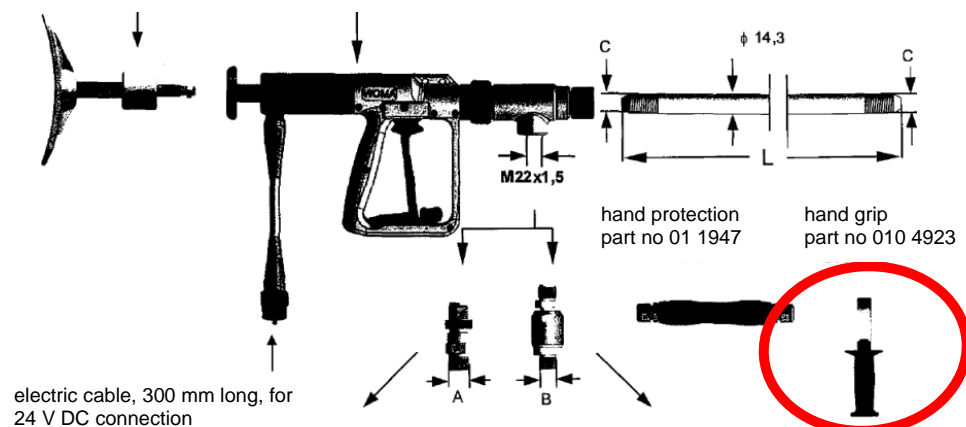

High-pressure pistol with second hand grip



Personal safety equipment for hand and legs (up to 500 bar)